

Purchase at www.neutron.supply

Neutron Supply

255 East 17th Street, Paterson NJ 07525 Tel: 973.261.9596

E-Mail: info@neutron.supply www.neutron.supply

© 2023 Neutron Supply. All Rights Reserved

LED LINEAR STRIP LIGHT 4FT / 8FT

SPECIFICATIONS

	4FT	8FT
Size	4FT	8FT
SKU	CLF1010	CLF1011
Lens	Single	Single
Wattage	3 Watts Select: 40/30/20W	3 Watts Select: 80/60/40W
Lumens	3 Lumens Output: 5600/4200/2800	3 Lumens output: 11200/8400/5600
Efficacy (LM/W)	140	140
Volt	120-277VAC@50/60Hz 120-347VAC@50/60Hz	120-277VAC@50/60Hz
CCT	3 CCT Select 4000/5000/5700K	3 CCT Select 4000/5000/5700K
CRI	>80	>80
THD	<20%	<20%
Surge Protection	2KV	2KV
DLC Product ID	PLLDF0T2VYI7	PLAO5OG6IWXU
IP Rating	IP20	IP20
Power Factor	>0.95	>0.95
Operating Temp	-22°F to 113°F (-30°C to +45°C)	-22°F to 113°F (-30°C to +45°C)
Warranty	5 Years	5 Years
Certificates	UL/cUL, DLC 5.1 Premium	UL/cUL, DLC 5.1 Premium



FEATURES / PERFORMANCE

- Easy Installation
- LED Type: 2835
- Motion Sensor Available
- Life Time > 50,000Hrs
- Dimming Range 10-100%,
- 3CCT and 3 Wattages Selectable
- Beam Angle 90 Degrees
- Rebate Eligible

CONSTRUCTION

- Frosted PC Lens
- Cole-Rolled Steel Housing
- Finish: White

MOUNTING

- Surface Mounted
- Wall Mounted
- Pendant Installation
- Linkable Installation

APPLICATION

- Industrial lighting
- Warehouse lighting
- Retail / Supermarket lighting
- Parking garage

CONT. MOUNT QTY

- 4FT: 15PCS
- 8FT 70W: 10PCS
- 8FT 80W: 8PCS
- 8FT100W: 6PCS

ACCESSORIES INCLUDED



Microwave Motion Sensor (Merrytek)



Emergency Battery Backup



Linkable Mounting Bracket



Pendant Accessories

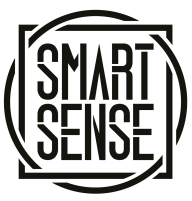

Purchase at www.neutron.supply

Neutron Supply

255 East 17th Street, Paterson NJ 07525 Tel:
973.261.9596

E-Mail: info@neutron.supply www.neutron.supply

LED LINEAR STRIP LIGHT 4FT / 8FT

DIMENSIONS

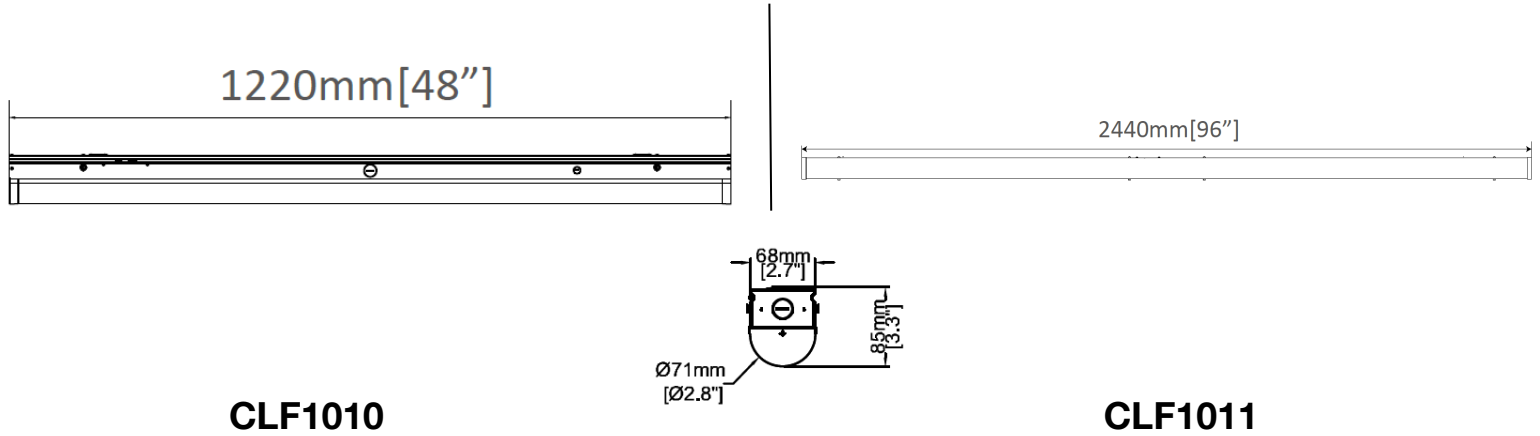

PACKAGE

SKU / WATT	PRODUCT WEIGHT (kg) N.W /PC	PRODUCT WEIGHT (kg) G.W/PC	PACKAGE WEIGHT (kg) N.W /CTN	PRODUCT WEIGHT (kg) G.W/CTN	CARTON SIZE (mm)	Q'ty/ CTN (PCS)	20GP (PCS)	40HQ (PCS)
4FT	1.68	2.63	10.08	11.43	11260*265*200	6	2490	6522
8FT	3.25	4.54	13.00	14.60	2480*170*200	4	1244	3116



Purchase at www.neutron.supply

Neutron Supply

255 East 17th Street, Paterson NJ 07525 Tel: 973.261.9596

E-Mail: info@neutron.supply www.neutron.supply

© 2023 Neutron Supply. All Rights Reserved

DESIGNLIGHTS CONSORTIUM



CLF1010

Classification	Premium
Primary Use	Low-Bay Luminaires for Commercial and Industrial Buildings
Reported Input Wattage	40 W
Reported Light Output	5600 lm
Reported CCT	4000 K
Reported CRI (Ra)	84
Product ID	S-0DL73W
DLC Family Code	GGGGYC
Listing Status	Listed
Date Qualified	01/19/2023

CLF1011

Classification	Premium
Primary Use	Low-Bay Luminaires for Commercial and Industrial Buildings
Reported Input Wattage	77 W
Reported Light Output	10000 lm
Reported CCT	4000 K
Reported CRI (Ra)	85
Product ID	S-NC5ISP
DLC Family Code	GGGGYC
Listing Status	Listed
Date Qualified	01/19/2023

Project Name:
Type:
Catalog Number:
Voltage:
Approved By:
Date: